

## LEWA ecodos®

High-quality diaphragm metering pumps  
for low pressures



- hermetically sealed
- low life cycle costs
- safe and reliable

## For high requirements at low pressures: LEWA ecodos



The chemical industry:  
LEWA ecodos pumps are used,  
for example, for dosing of dye.



The petrochemical industry:  
used for gentle metering of highly viscous  
fluids in the production of biofuels.

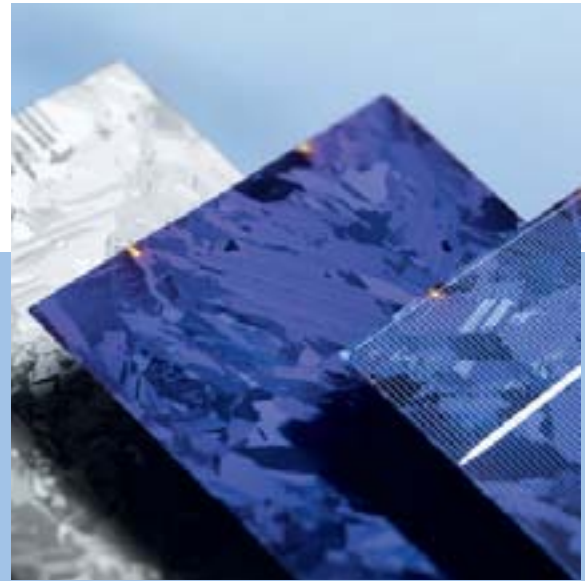

The plastics industry:  
LEWA ecodos pumps are used, for example,  
for polymerization processes in the manufacture  
of solar cells.

### **Quality has never been so efficient and safe**

LEWA ecodos diaphragm metering pumps are the ideal safe and efficient solution to meet all your specific metering and conveying application requirements in the low pressure range up to 20 bar (300 psig). Their performance ranges from 0.4 to 1500 l/h (0.1-400 USgph) per pump head; and the pump heads can be simply combined to create multiplex pumps. The patented 4-layer PTFE sandwich-diaphragm provides increased safety and high-precision metering. Unique advantages which make the LEWA ecodos series stand out from its competitors:

- Hermetically sealed diaphragm pump up to 20 bar (300 psig)
- Safe due to a 4-layer PTFE sandwich-diaphragm
- Integrated diaphragm monitoring system (as standard)
- Diaphragm service life of more than 16,000 operating hours
- Continued operation possible even if damages occur
- High metering accuracy:  $\pm 1\%$
- Stainless steel, PVC or electrically conductive PTFE pump heads
- Unique: Available in 13 performance ratings, also as multiplex pumps
- Efficient: Low cycle costs



The pharmaceutical industry: LEWA ecodos in hygienic design meets the high demands of the pharmaceutical industry for extruding tablets.



The cosmetics industry: LEWA ecodos in sanitary design guarantees problem-free cleaning in the manufacture of skin care products.



The food industry: sterile and reliable production, for manufacturing gelatin or fruit gums.

**Maximized performance and efficiency – in numerous sectors**

With its flexible design, the LEWA ecodos series is ideal for a wide range of industrial applications; ranging from alcohol to suspensions.

LEWA ecodos offers the highest precision, safety and reliability when handling emulsions or suspensions, alkalis or acids, paints or varnishes, cleaning agents or solvents, grease or oil, hazardous or toxic liquids. The LEWA ecodos series provides excellent and proven results in the following sectors:

- Chemical & biochemical
- Food & beverages
- Pharmaceutical & personal care
- Power plant engineering
- Mineral oil industry, Petrochemical industry
- Paper & pulp industry
- Environmental & process



# For availability, safety and economic efficiency: LEWA ecodos technology

## **The availability and operational safety of your installations depends on the quality of the individual components. LEWA ecodos helps to increase availability.**

With its cutting-edge design, the LEWA ecodos series exhibits numerous special diaphragm pump features. It is much more chemically resistant than conventional diaphragm systems and is more durable, also much safer. LEWA ecodos has a very wide application range and is ideal for all types of fluids, solvents or diffusing fluids. Moreover, LEWA ecodos systems are hermetically sealed – even with a damaged working diaphragm.

## **Valves for various applications**

Even the standard valve has reduced susceptibility to malfunction. Special valves are used for suspensions to ensure perfect operation.

## **4-layer safety diaphragm for complete tightness**

- 2 working diaphragms
- 1 monitoring diaphragm
- 1 pressure-resistant safety diaphragm

Two working diaphragms result in double safety: If one is damaged, the other one continues to operate. If the second diaphragm is also faulty, it will be indicated by the monitoring diaphragm. The fourth pressure-resistant diaphragm ensures the hermetic seal; ensuring production is completed without risks.

## **PTFE for added chemical resistance**

PTFE is resistant to almost any fluid, e. g. solvents and diffusing fluids. It offers a greater application range and higher safety margins. Furthermore, it assures longer life cycles.

## **Longer diaphragm service life; more than 16,000 operating hours**

LEWA ecodos safety diaphragms have a service life of more than 16,000 operating hours, i.e. two years of continuous operation. Therefore, the warranty period for diaphragms is two years.

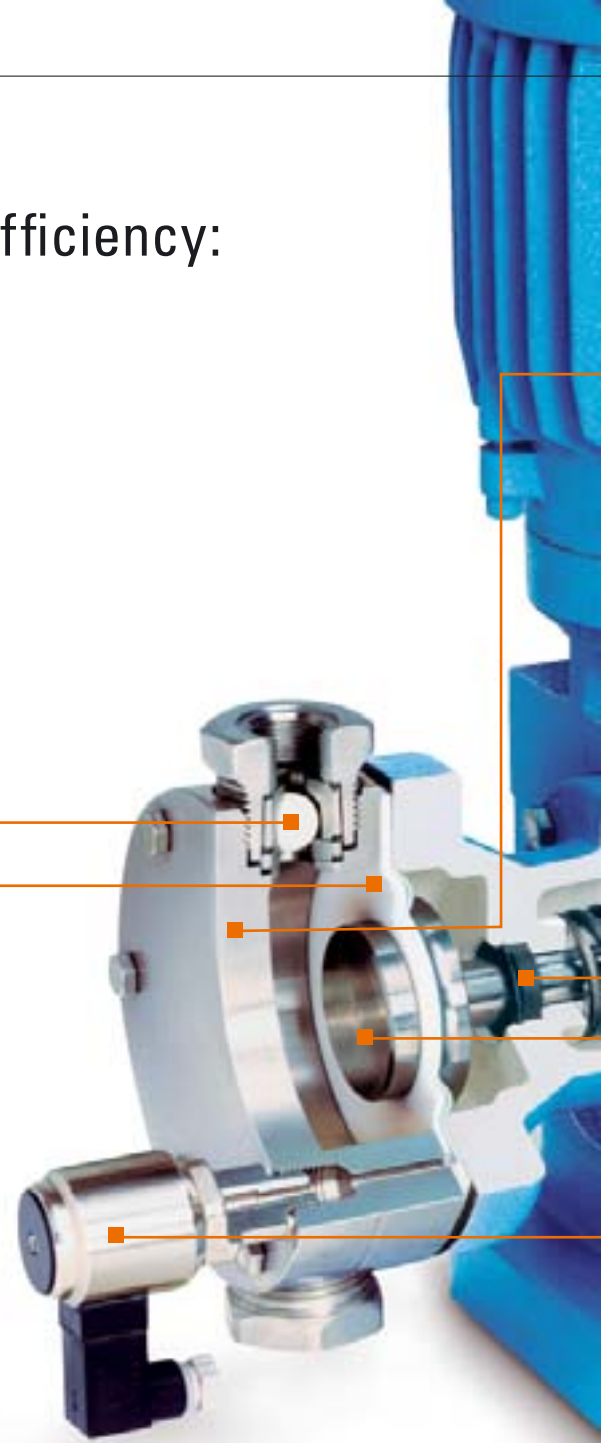



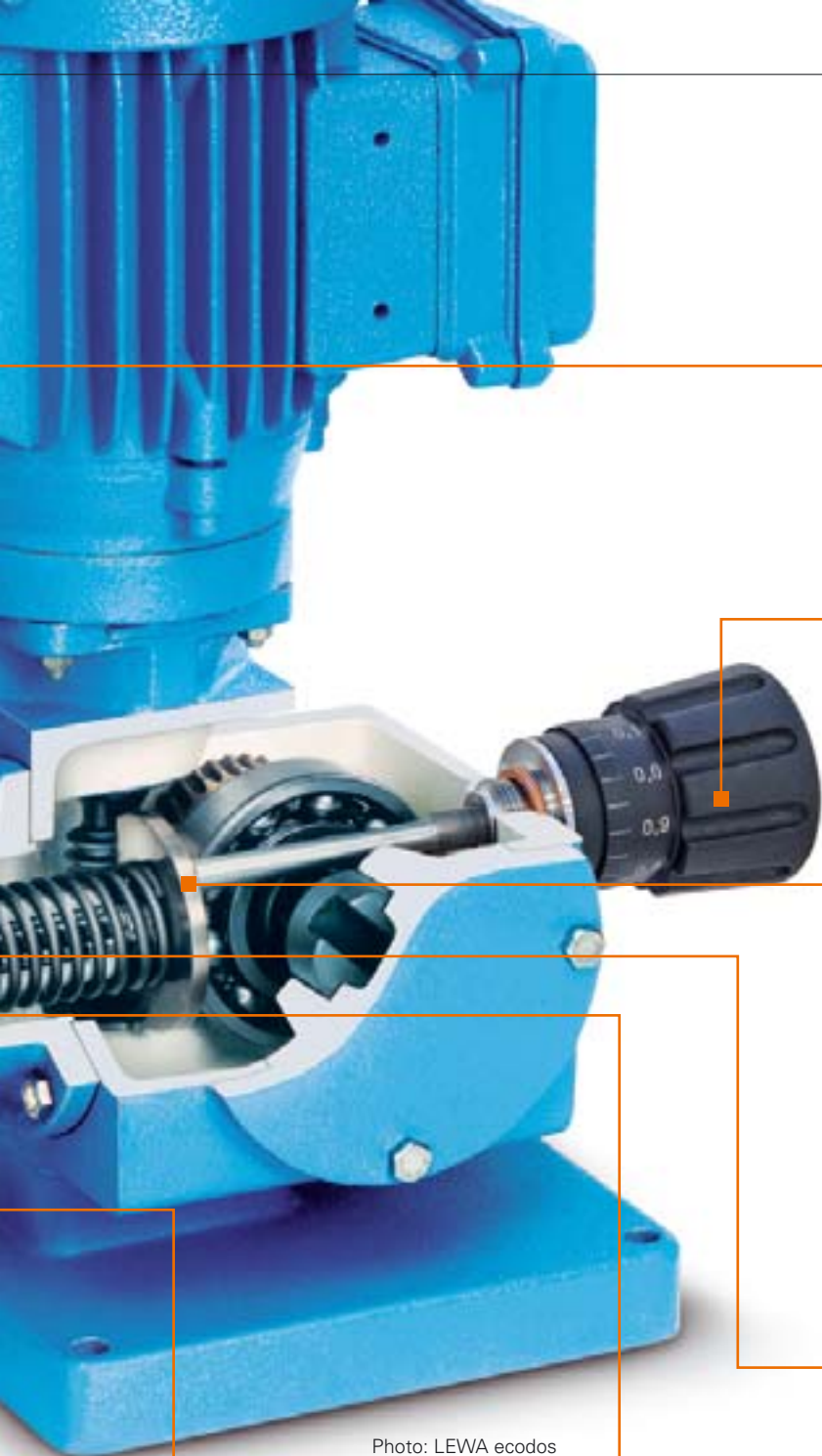

Photo: LEWA ecodos

### **Diaphragm monitoring system for increased safety**

The pressure-controlled diaphragm monitoring system is integrated as standard. It reliably indicates damage immediately. Local and/or remote indication are/is possible via:

- a pressure switch (IE 4)
- a contact pressure gauge (similar to pressure switch but with a display)
- a pressure gauge
- hose nipples for uncritical fluids

### **Minimum dead spaces: shorter dwell period**

The optimized construction of the pump head ensures that the amount of process fluid in the operating chamber is kept to a minimum. The design of the fluid passages results in perfect flushing, draining and drying procedures.

### **The ideal material for each fluid**

The standard material is stainless steel 1.4571(316Ti). Other materials are PVC, PVDF, Polypropylene and electrically conductive PTFE.

### **High metering accuracy, gentle conveying**

The metering pumps provide high metering accuracy and gentle conveying. Precise adjustment of the stroke (manually or electrically) and adjustment of the stroke frequency via a frequency inverter are possible. Reproducibility of the settings is better than  $\pm 1\%$ .

### **Robust drive units for continuous operation**

continuous operation  
The LEWA ecodos drive units are designed for continuous operation. Spring-cam drive units are used up to LEWA ecodos 550; variable eccentric drive units are used for higher performances.

### **Hermetically sealed pump heads**

The low-maintenance pump heads are hermetically sealed. The diaphragm drive housing is sealed from the drive unit to prevent oil leakages when replacing a pump head.

# For the most varied requirements: Three LEWA ecodos pump heads



Whether as a single pump, e.g. with heads designed to be CIP/SIP



Or as multiplex pumps, e.g. for recipe metering



Or as feed pumps, e.g. for high performance with low pulsation



Variable stroke setting:  
electrical stroke adjustment EHV

LEWA ecodos series pumps are available in 13 performance ratings and can be combined to form multiplex pumps. The pump heads are constructed of stainless steel, PVC, PVDF or electrically conductive PTFE. With its individual controls and a complete range of accessories, LEWA ecodos can be adapted to any application. And it goes without saying that LEWA ecodos pumps meet all the specific demands of integration in automated installations.

### High metering accuracy: $\pm 1\%$

LEWA ecodos diaphragm pumps are characterised by their extremely high metering accuracy. Flow rate fluctuations are less than  $\pm 1\%$  in a stroke length adjustment range of 5:1.

### Variable flow rate adjustment

Flow rates can be variably adjusted: the stroke length via a handwheel or actuator, the stroke frequency via a motor with frequency inverter. The recommended adjustment range via the stroke length is 5:1 and can be additionally extended via the stroke frequency.

### Precise stroke adjustment: manually or electrically

Stroke adjustments are operator friendly and display the precise stroke length via:

- Manual stroke adjustment
- Electrical stroke adjustment with stroke length adjustment signal and end position cut-off up to LEWA ecodos 350 with integrated positioner, guide signal and 4-20 mA (factory setting), an optional 0-20 mA is available.
- LEWA ecodos 750 and higher with electrical stroke adjustment, emergency adjustment via a handwheel is also possible

### Precise speed adjustment via frequency inverter

The adjustment range can be easily extended via a frequency inverter. Inverter and pump are supplied function tested; eliminating the need for complex optimisation and parameterization. LEWA also supplies complete control cabinets on demand:

- Frequency inverter for motor power of 0.37–7.5 kW/0.3 to 2.0 HP
- Designed as 1-phase or 3-phase devices



Perfect stroke frequency:  
LEWA ecodos with frequency inverter



### Drive options

The drives are NEMA motors of well-known manufacturers. The following drives are fitted as standard:

- 3-phase motors 230/400V 50Hz or 460V 60Hz
- Degree of protection IP55, insulation class F
- Optionally with protection class CL2 DIV1 Grp BCD

Other motors, voltages and degrees of protection available on request.

### Valve options

Various insert rings for the valve seats of the stainless steel pump heads are available to ensure perfect adaptation to the fluid.

- PTFE
- FPM
- Polyurethane
- Valve seats made of hardened stainless steel

### Control options

LEWA supplies complete controls, e.g. for proportional or batch metering. We will provide you with detailed information on request.

### Instrumentation options

The contactors are installed at the last drive element and determine the number of pump strokes, e.g. for batch control and totaliser.

- Inductive proximity switch
- Explosion protection Exi
- Degree of protection IP65



Field-proven controls:  
e.g. for proportional or batch metering

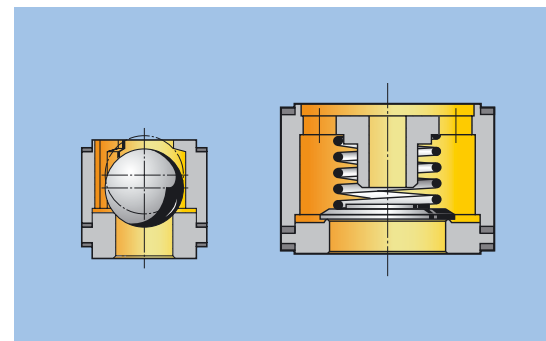

Low wear valves for various applications

# For extra production safety: LEWA ecodos accessories

**Intelligent accessories make the most of your application or plant.**



Pulsation dampers

## **Pulsation dampers**

Metering pumps work in pulses; on each pump stroke, fluid is accelerated and then decelerated. Pulsation dampers can be required for two reasons:

- To reduce excessively high pressure fluctuations
- To generate a flow rate that is almost continuous

LEWA has the expertise as well as the accessories to optimally tailor pumps and installations to one another.



Safety valve

## **Safety valves**

LEWA safety valves prevent pressure overloads in the pumps and installation. Metering pumps, which deliver by force, must always be protected with a safety valve if there is a risk that the discharge pipe could close during operation of the pump (e.g. by sedimentation in the pipe).

## **Further options**

Further accessories (e.g. injection points, DIN and ANSI flanges or wear parts kits) are also available on request.

## **Strainers**

Many fluids being conveyed contain impurities. These can lead to faults in the metering pump valves – from slight fluctuations in the metered flow to complete failure. In order to reliably avoid these effects, LEWA recommends fitting strainers in the suction pipelines.

## **Pressure retaining valves**

LEWA pressure retaining valves prevent uncontrolled flow through the pumps (excessive delivery). This occurs when the pressure on the suction flange is greater than on the discharge flange, which can be caused either statically or dynamically. The retaining pressures are generally low.

## **Expert installation**

Let LEWA advise you on matters of pump design and expert installation. We are also happy to supply you with a fully-functional system or offer suitable components or a finished installation with suction and discharge pipe line.



Expert installation



## LEWA ecodos – Technical data

Model		2	4	6	12	25	50	90	180	350	550	750	1100	1500
Identical symbols can be combined				●	◆	●	◆	●	◆	◆		■	■	■
Output eff. (Qmax at P max)	gph	0.65	1.3	2	3.6	8.0	15	30	51	100	173	242	296	360
	lph	2.5	5	7.9	14.2	32	57	114	195	379	656	916	1119	1362
Viscosity		500			400	500	400	500	300	500				
Stroke frequency at 60 Hz	spm	32	64	101	182	101	182	101	173	173	173	138	173	207
Motor (simplex pump) 1725 rpm	HP	.33	.33 *3	.33	.33	.33	.33	.50	.75	.75	1.0	1.0	2.0	2.0
Approx. weight (simplex incl. motor)	lbs	33	33	33	33	33	33	51	51	66	132	168	168	168
	kg	15	15	15	15	15	15	23	23	30	60	76	76	76

### Version S, stainless steel 1.4571 (316Ti) pump head

Operating pressure	psig/bar	280/20			145/10			108/7.5		73/5 [108/7.5 bar] *1				
Permissible operating temperature	°C & °F	-10/80 °C & 14/176 °F *2												
Valve type		Ball valve											Plates	
Standard connections		1/2" NPT (F)							1"NPT(F)		ANSI 1" RF Flange			

### Version P, PVC-H pump head

Operating pressure	psig/bar	174/12			145/10			108/7.5		73/5 [108/7.5 bar] *1				
Permissible operating temperature	°C & °F	0/60 °C & 32/140 °F *2												
Valve type		Ball valve											Plates**	
Standard connections		1/2" NPT (F)							1"NPT(F)		ANSI 1" RF Flange			

### Version F, PVDF fluorinated plastic pump head

Operating pressure	psig/bar	174/12			145/10			108/7.5		73/5 [108/7.5bar] *1				
Permissible operating temperature	°C & °F	-10/80 °C & 14/176 °F *2												
Valve type		Ball valve											Plates**	
Standard connections		1/2" NPT (F)							1"NPT(F)		ANSI 1" RF Flange			

PTFE sandwich-diaphragm

Ball valves with oxide ceramic ball, Gylon or PTFE seal rings

\*\* Hastelloy valve springs

## LEWA ecodos – Assembly dimensions

LEWA ecodos type	L [mm]	W [mm]	ΔW [mm]	H [mm]
2 - 50	360	220	85	480
90 - 350	425	220	120	570
550	595	270	175	660
750 - 1500*1	500	400	–	800
750 - 1500*2	500	900	250	450

\*1 = For drive elements without stroke adjustment

\*2 = for operating temperature >40°C/104°F consult LEWA

\*3 = 3450 rpm motor

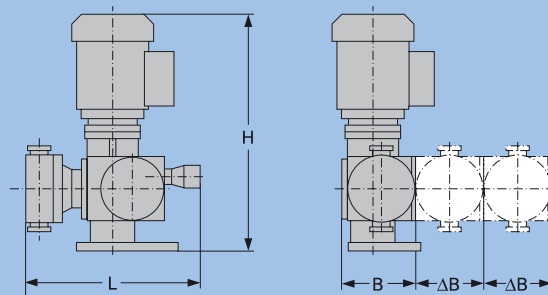

Standard - Vertical Motors

Optional - 750/1100/1500 - Horizontal motor assembly.

The dimensions differ depending on the fitted pump head, the motor and the instrumentation.

# For every occasion: The LEWA product range



LEWA micro-flow metering pumps

## For laboratories and & pilot plants: LEWA micro-flow pumps

These micro metering pumps with hydraulically actuated metal diaphragms are primarily used in laboratories and for test procedures in pilot plants.

### Performance range

Flow rate	up to 0.04m <sup>3</sup> /h (10.5 USgph)
Discharge pressure	up to 560 bar (8,100 psig)



LEWA ecoflow

## For medium to high pressures: LEWA ecoflow

LEWA ecoflow offers the most advanced metering diaphragm pumps with leak-free safety for medium and high pressures – not least because of the unique Diaphragm Protection System (DPS).

### Performance range

Flow rate	up to 10m <sup>3</sup> /h per pump head (2,650 USgph)
Discharge pressure	up to 1,200 bar (17,400 psig)



LEWA triplex process diaphragm

## For sterile applications: LEWA Sanitary&Hygienic

LEWA supplies special sanitary and hygienic diaphragm pumps for metering tasks in hygienic, aseptic or sterile processes, whether for food and beverages or for pharmaceuticals and cosmetics.

### Performance range

Flow rate	up to 4.5 m <sup>3</sup> /h per pump head (1,200 USgph)
Discharge pressure	up to 350 bar (5,100 psig)



LEWA metering systems and metering installations

## For high pressures: LEWA process diaphragm pumps

The leak-free LEWA process diaphragm pumps for high flow rates are the secure standard in high-pressure process technology. Using LEWA triplex process diaphragm pumps, even critical, toxic or flammable liquids can be conveyed safely. Even extremely low viscous, nonlubricating fluids or abrasive suspensions can be handled successfully.

### Performance range

Flow rate	up to 180m <sup>3</sup> /h (47,520 USgph)
Discharge pressure	up to 1,200 bar (17,400 psig)

## For closed control loops: LEWA metering systems

LEWA is the first point of contact in the market for high-performance yet economically designed metering systems. These are modular combinations of pumps, valves and controls for stroke lengths and speeds, flow meters (volume or mass flow) and controllers. The metered flow is controlled in a closed control loop.

## For process automation: LEWA metering packages

LEWA metering and mixing packages for process automation are available either as standard variants ready for connection, or designed by LEWA specifically for the task on the customer's request. LEWA can supply complete, ready to operate problem solutions. Our services range from engineering through to commissioning – including individual package controls, process visualization, logging of operational data and external interfaces to the process control system

For more information, request our brochures.

# For the highest demands: LEWA engineering & services



Profit from LEWA expertise in the planning period, stage, the design and during operation

## Consultancy & engineering for particular tasks

With over 10,000 successful applications, LEWA has a very wide range of application expertise around the world. Profit from our experience. We see ourselves as a supplier of solutions and systems for any application involving the conveying, metering and mixing of gases and liquids. We can thus provide tailor-made solutions, from the smallest single unit to the largest inline installations, as well as process engineering consultancy for complex tasks. Solutions that meet specific process requirements.

- Fluid assessment
- Installation calculations
- Comparable process engineering applications
- Individually designed concepts
- Commissioning and service
- Seminars and on-site-training

## Global service network for greater availability

LEWA follows its customers around the world. With 15 subsidiaries and numerous authorized agencies, you will find us in all major countries. This local presence is also critical for the successful implementation of international projects. Regular maintenance guarantees the reliability and, particularly, the profitability of a pump system. This is where we can help out with our comprehensive expertise. We look after LEWA installations – worldwide. And we ensure that original spare parts can be supplied and will remain available for many years.



Quickly on site: whether for consultancy, maintenance or servicing, local presence takes top priority at LEWA



For the toughest environments: High levels of reliability even when used under tough conditions

# For short distances: LEWA at your service worldwide

## Germany / Headquarters

### LEWA GmbH

Ulmer Str. 10  
71229 Leonberg  
Phone +49 7152 14-0  
Fax +49 7152 14-1303  
lewa@lewa.de  
www.lewa.de

### LEWA HOV GmbH + Co KG

Neue Ramtelstr. 48  
71229 Leonberg  
Phone +49 7152 6091-0  
Fax +49 7152 6091-59  
hov@hov.de  
www.hov.de



## Austria

### LEWA Pumpen GmbH

1150 Vienna  
Phone +43 1 8773040-0  
info@lewa.at  
www.lewa.at

## Brazil

### LEWA Bombas Ltda.

04378-400 São Paulo - SP  
Phone +55 11 56770466  
info@lewa.com.br  
www.lewa.com

## Bulgaria

### LEWA – Technical Office Sofia

1421 Sofia  
Phone +359 2 8654088  
lewa.bg@lewa.at  
www.lewa.at

## China (P.R.C.)

### LEWA Pumps (Dalian) Co., Ltd.

116600 Dalian  
Phone +86 411 8758-1477  
sales@lewa.cn  
www.lewa.cn

## Czech Republic

### LEWA Pumpen spol. s.r.o.

602 00 Brno  
Phone +420 5 43236052  
office@lewa.cz  
www.lewa.at

## France

### LEWA S.A.S.

78500 Sartrouville  
Phone +33 1 308674-80  
info@pompes-lewa.fr  
www.lewa.fr

## Hungary

### LEWA Kft.

1012 Budapest  
Phone +36 1 2240403  
lewa.hu@lewa.at  
www.lewa.at

## Italy

### LEWA S.R.L.

20020 Arese (Mi)  
Phone +39 02 935826-60  
info@lewa.it  
www.lewa.it

## Norway

### LEWA AS

4319 Sandnes  
Phone +47 52 9091-00  
info@lewa.no  
www.lewa.no

## Poland

### LEWA Sp. z o.o.

00-159 Warsaw  
Phone +48 22 6358204  
info@lewa.pl  
www.lewa.pl

## Romania

### LEWA Romania s.r.l.

050579 Bucharest  
Phone +40 21 4107340  
info@lewa.ro  
www.lewa.at

## Singapore

### LEWA PTE LTD

Singapore 129808  
Phone +65 686 17127  
info@lewa.sg  
www.lewa.sg

## Spain

### LEWA Hispania, S.L.

08020 Barcelona  
Phone +34 93 2247740  
info@lewa.es  
www.lewa.es

## Switzerland

### LEWA Pumpen AG

4153 Reinach 1  
Phone +41 61 7179400  
info@lewa-pumpen.ch  
www.lewa-pumpen.ch

## Ukraine

### LEWA Ukraine LC

03039 Kiev  
Phone +380 44 52796-31  
lewa.ua@lewa.at  
www.lewa.at

## UAE / Dubai

### LEWA GmbH (LEWA Branch)

Dubai Airport Free Zone, UAE  
Phone +971 4 2993969  
lewa@lewa-dubai.ae  
www.lewa.ae

## Your local contacts:

### USA / Eastern North- and Middle America

#### LEWA, Inc.

Holliston, MA 01746  
Phone +1 508 429-7403  
sales@lewa-inc.com  
www.lewa-inc.com

### USA / Western North- and Middle America

#### LEWA, Inc.

Houston, TX 77079  
Phone +1 713 577-5392  
houston@lewa-inc.com  
www.lewa-inc.com

### USA Gulf Coast – Oil & Gas Production

#### Capital Process Equipment, Inc.

Houston, TX 77029  
Phone: +1 713 673-5161  
rfletcher@capitalprocess.com  
www.capitalprocess.com

Find more LEWA subsidiaries  
at [www.lewa.com](http://www.lewa.com)