

Fluid Power Actuators and Control Systems

rotork® Fluid Systems

Established Leaders in Valve Actuation

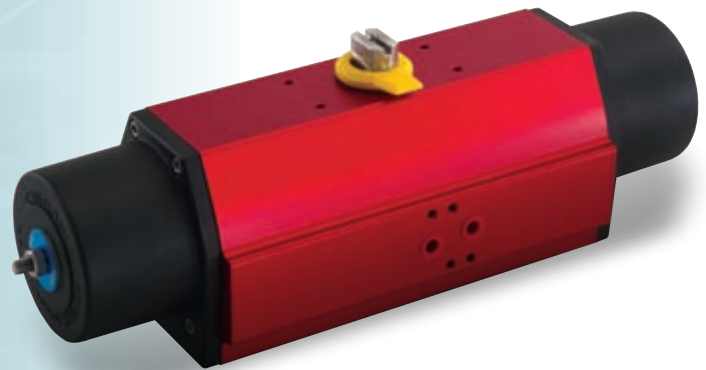
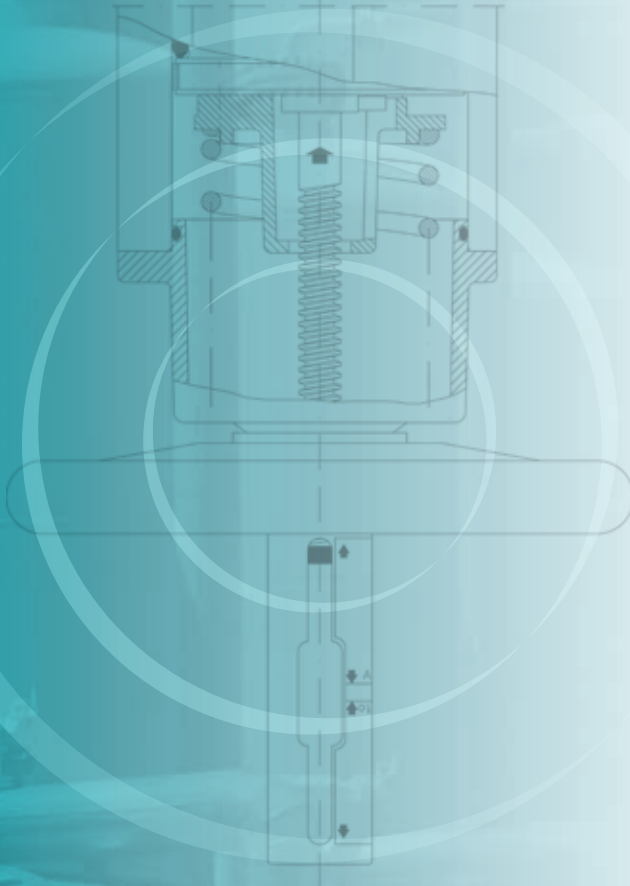

The
REMOTE CONTROL®
Range

RC200

Compact Scotch-Yoke Actuators
for Quarter-Turn Valves

Rotork Actuators – Quality Controlled

Since the company was founded in 1957, Rotork has become the standard for excellence in the field of valve and damper automation for the oil, gas, power, water and waste treatment industries around the world.

As established leaders in actuation technology, we owe our success to a commitment to quality at every stage, and at every level, of Rotork's operations.

At the heart of the company is an exceptional workforce – the highly trained, forward thinking engineers, technicians, and sales support staff who each play a crucial role in maintaining Rotork's unrivaled reputation for innovation, reliability and first class after sale support.

With several fluid power factories and additional *Centres of Excellence* located around the globe, we are able to offer creative solutions and design systems for virtually any application – from subsea hydraulics to the most sophisticated yet simple fluid power control system.

Contact Rotork for your operational or safety application requirements. We will work with you from conception, to design, to manufacture, to installation, and finally to maintenance and service support.



Remote Control Range RC200 Compact Scotch-Yoke Actuators

The Rotork Fluid Systems RC200 pneumatic actuator features a modern scotch yoke mechanism that provides high start and end torque output in a very compact package. It is available in both double-acting and spring-return configurations with an optional integral manual override. Spring-return actuators feature springs that are safely contained within an epoxy coated cartridge. Pistons are guided in two places by high performance bearings which ensure proper alignment and long seal life. Adjustable travel stops are available in both directions.

RC200 actuators have the lowest weight and the smallest external dimensions of any actuator with an equivalent torque output. This yields a compact and light yet robust valve/actuator package, particularly when a manual override solution is required. Another benefit is that they have less stroke volume than comparable rack and pinion actuators, providing a significant saving in the use of compressed air.

Quality

RC200 actuators are manufactured under strict quality control in an ISO 9001:2000 / 14001:2004 environment. They comply with all standard international requirements and are CE marked according to PED and ATEX.

We use only top-quality materials in a precisely engineered and manufactured product so our actuators are very long lasting. We are proud to provide a unique three-year warranty.

Efficiency

Unlike rack & pinion designs often offered by our competitors, the RC200 with its scotch-yoke drive gives at least 50% more torque in the end positions, where most valves require it.

Reliability

Every Rotork Fluid Systems actuator is built to provide long and efficient service with a minimum of maintenance. The design, engineering and materials used in their construction ensure optimum performance even in the harshest of environments.

Inside The RC200 Actuator

Operating Pressure: 2-10 bar (30-145 psi)

Torque Output: Up to 4,400 Nm (39,000 lbf-in)

Temperature Ranges:

Standard:	-20 to +80 °C	(-5 to +175 °F)
High:	0 to +150 °C	(+30 to +300 °F)
Low:	-40 to +60 °C	(-40 to +140 °F)
Arctic:	-47 to +60 °C	(-52 to +140 °F)

Extra Corrosion Protection:

RCT: hard anodise / low friction polymer treatment.
 Epoxy coating.
 Offshore or other finish to meet customer specifications.
 Stainless screws and drive shaft (standard for RC210 – 260).

Standards:

Solenoid valve connection: NAMUR.
 Fitting accessories: VDI/VDE 3845, NAMUR.
 Fitting to valve: Hole pattern, centering ring ISO 5211, DIN 3337, NAMUR.
 Stardrive shaft: ISO 5211 with 90° □ and DIN 79 with 45° ◇ and NAMUR.

Operating Medium:

Air, inert gases (non-dangerous fluids, group 2 according to directive PED 97/23/EC).

RC200 actuators also available for water or oil hydraulics.

CE Marking: CE marked according to PED and ATEX.

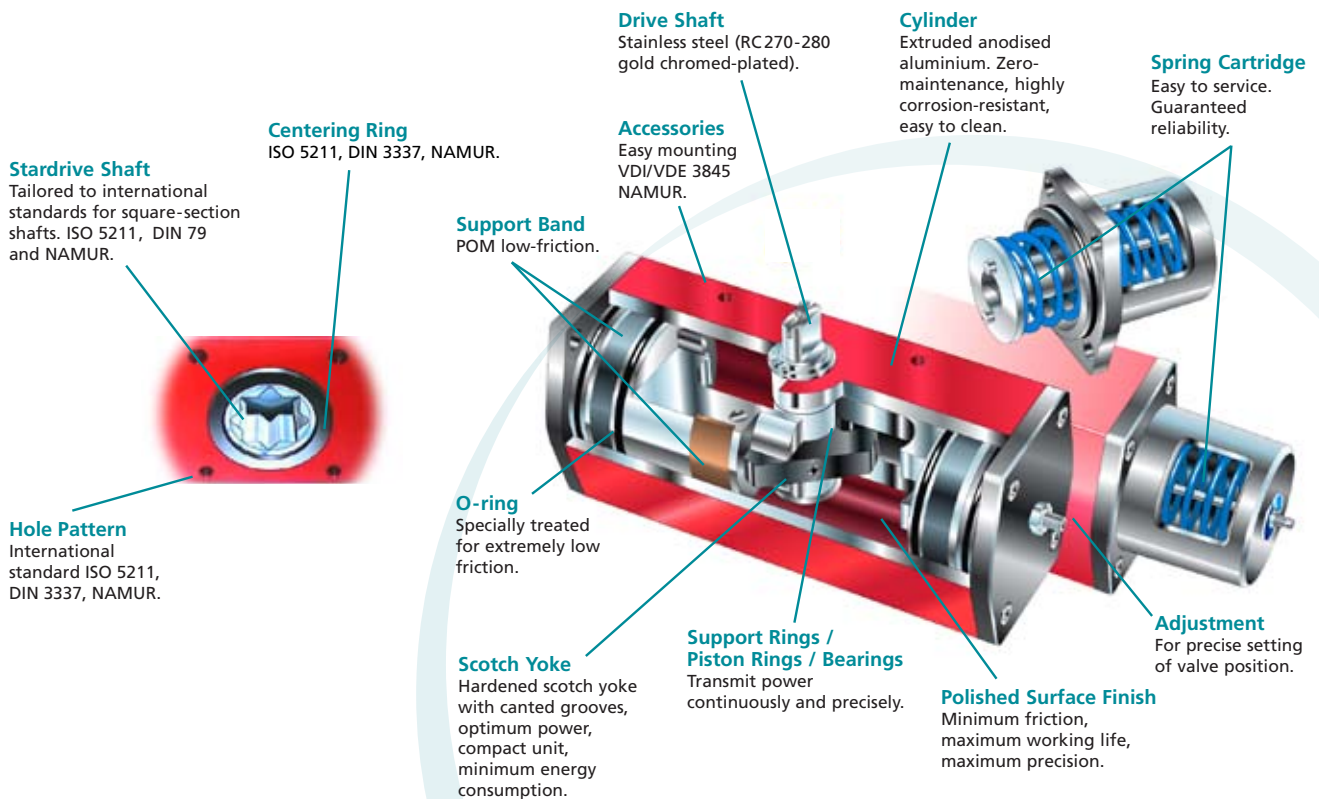

Features and Benefits

- For either on/off and modulating applications.
- Lightweight, compact design.
- Double-acting and spring-return configurations.
- Pre-tensioned springs for safety.
- High torque in the end-of-stroke positions.
- Connections and mounting according to international standards.
- High efficiency, low air consumption.
- Housing in anodised aluminium.

Note on the RC265

The RC265 size is an addition to the 200 series actuator family. This model was added as an optimum solution to a torque gap between the 260 and 270 sizes. It incorporates all the standard features of the RC200 series. An added feature unique to the 265 model is adjustable limit stops that allow ±4° adjustment of both open and close positions. An external stop cam can be custom machined for different degrees of rotation.

M1 Manual Override



RC240-SR M1

Compact Declutchable Handwheel

The override is integrated in the endcap of the actuator and can be fitted to all RC200 series units in both double-acting and spring-return configurations. The RC M1 manual override is the optimum solution for users requiring a compact unit of minimum weight and size.

- For both double-acting and spring-return actuators.
- Lightweight yet rugged design.
- Safe, non-rotating handwheel, eliminates use of levers for manual operation.
- Valve/actuator can be locked in either open or close position.



RC280-SR M1
With control accessories

See the comparison below of an RC200 M1 with a rack and pinion actuator equipped with an intermediate gearbox providing the override function. Note that the installed height of an RC200-DA with M1 override is the same as an RC200 actuator without manual override and is significantly less than that of an actuator/gearbox solution.

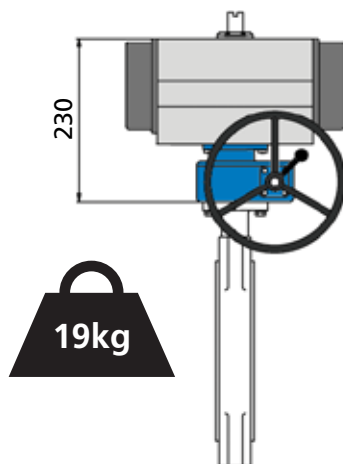

Rack & pinion actuator with
intermediate gearbox

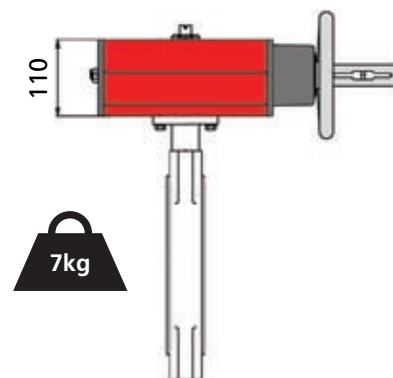

RC240-DA M1

Fitting Accessories

The Right Accessory Solutions

Valves and actuators only perform as well as the solution is engineered. With decades of experience engineering fluid power valve automation for a multitude of applications and markets, you can depend on Rotork to provide a reliable and safe automation solution to meet your requirements.



* Switch Boxes:

RC1990

Switch box, intrinsically safe IP66/67
 Temp: -50 to +110 °C / -58 to +230 °F
 ⚠ II 2 GD EEx d IIC T4, T5, T6
 Temp: -55 to +80 °C / -67 to +176 °F
 ⚠ II 2 GD EEx ib IIC T5, T6
 GOST R51330 .0-99 / R51330.1-99



RCE4L

Switch box IP67
 Option: ⚠ II 2 GD T80 / 100 °C
 EEx ib IIC T6 / T5



RC200 Dimensions

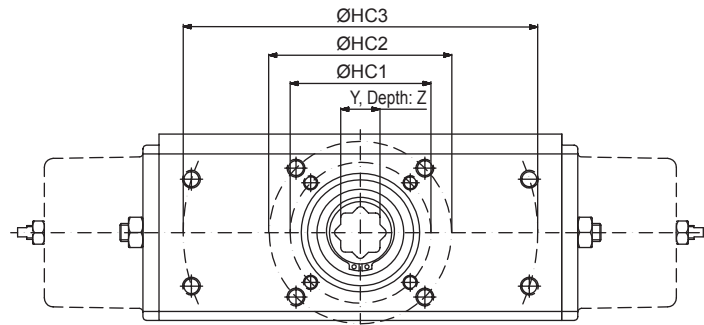

Fig. 1

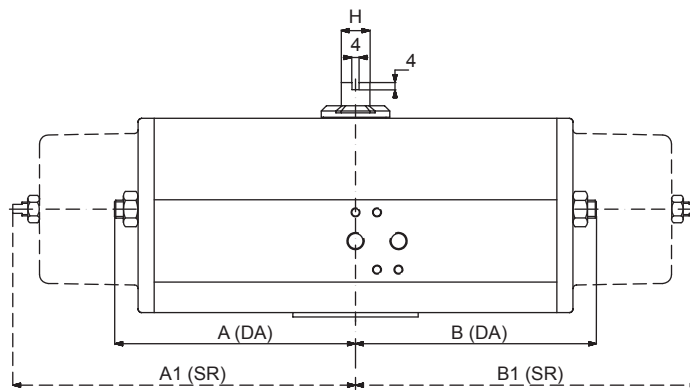

Fig. 2

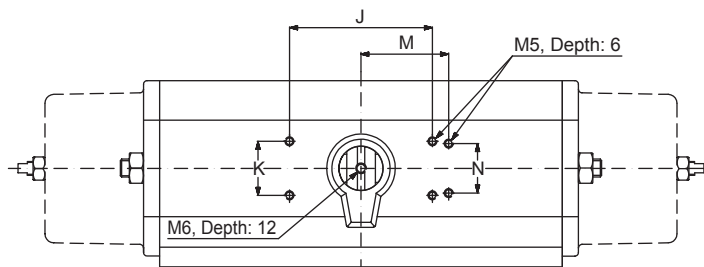
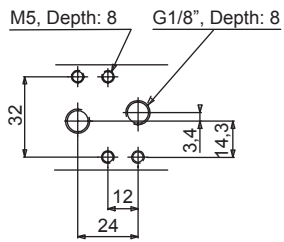

Fig. 3

Model	Dimensions (mm)																				Weight (kg)	
	Fig. 1					Fig. 2					Fig. 3				Fig. 4/4a						DA	SR
	HC 1	HC 2	HC 3	Y**	Z	A	B	A1	B1	H	J	K	M	N	C	E	F	G	U*	V		
RC210	F05	F07	-	14	19	45	98	45	150	10	35.4	35.4	40	30	32	41	75	16	35	2	1.2	1.5
RC220	F05	F07	-	14	19	98	98	150	150	10	80	30	-	-	32	41	75	16	35	2	1.6	2.2
RC230	F07	F10	-	17	30	65	135	65	200	16	80	30	-	-	49	55	110	25	55	3	3.5	4.2
RC240	F07	F10	-	22	30	135	135	200	200	16	80	30	-	-	49	55	110	25	70	3	4.9	7.0
RC250	F10	F12	-	22	37	90	190	90	285	22	80	30	-	-	69	75	155	35	70	3	9.4	12.4
RC260	F10	F12	-	27	37	190	190	285	285	22	80	30	-	-	69	75	155	35	85	3	12.5	18.5
RC265	F12	-	-	27	37	195	195	317	317	22	80	30	-	-	76	76	202	35	85	3	18.8	26.6
RC270	F14	-	170x110	36	64	145	300	145	510	40	130	30	-	-	110	110	248	60	100	4	32.0	45.0
RC280	F12	F16	234.7x97.2	46	64	300	300	510	510	40	130	30	-	-	110	110	248	60	130	5	42.0	68.0

RC200 Dimensions

RC210 to 240



Hole pattern for solenoid valves acc. to VDI/VDE 3845, NAMUR

RC250 to 280

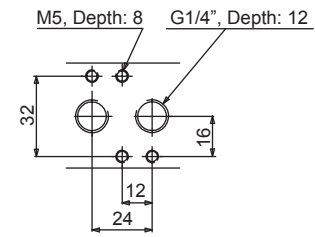

RC210 to 265

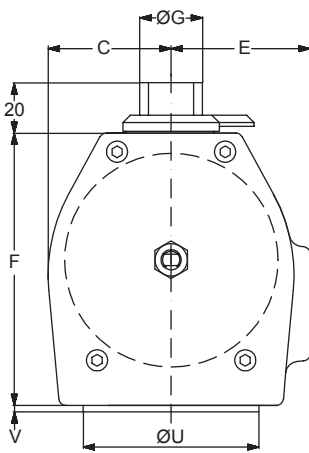

Fig. 4

SV= Mounting solenoid valves acc. to VDI/VDE 3845, NAMUR

U+V= Guide ring acc. to DIN 3337

RC270 to 280

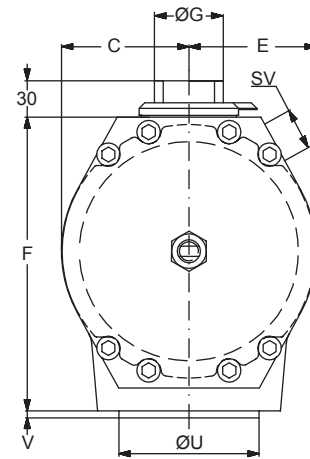

Fig. 4a

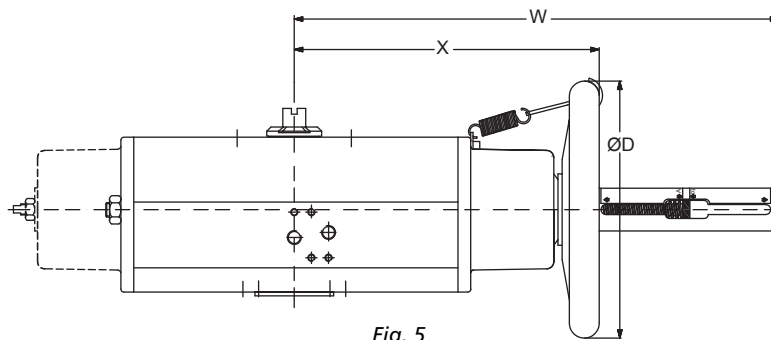

Fig. 5

Model	Dimensions (mm)			Weight w/M1 (kg)	
	D	X	W	DA	SR
RC210	180	145	295	2.2	2.5
RC220	180	145	295	2.7	3.2
RC230	180	190	345	4.8	5.3
RC240	180	190	345	5.8	7.1
RC250	320	295	505	13.8	15.2
RC260	320	295	505	16.3	20.2
RC265	320	370	600	24.3	31
RC270	400	515	812	47	57.7
RC280	600	490	812	55.1	80.7

U* = Guide ring for other hole circle on request.

Y** = Tolerance H9. The hole is octagonal and adapts to valve stems with squares at either 90° (ISO 5711) or 45° (DIN 3337) orientations.

Hole Dimensions (mm)			
ISO 5211	Circle Ø	Thread	Depth
F05	50	M6	11
F07	70	M8	14
F10	102	M10	17
F12	125	M12	21
F14	140	M16	25
F16	160	M20	32
170x110	-	M16	25
234.7x97.2	254	M16	25

Technical Data

Air Consumption DA

Free Air at 6 bar (dm ³)		
Model	Anti-clockwise rotation	Clockwise rotation
RC210	0.6	1.1
RC220	1.1	1.3
RC230	2.2	4
RC240	4.4	5
RC250	6.9	13
RC260	13.8	16
RC265	32	36
RC270	33	54
RC280	66	67

Air Consumption SR

Free Air at 6 bar (dm ³)	
Model	
RC210	1.1
RC220	1.3
RC230	4
RC240	5
RC250	13
RC260	16
RC265	36
RC270	54
RC280	67

Operation Times DA/SR

At 6 bar	
Model	Anti-clockwise and Clockwise rotation
RC210	<0.3
RC220	<0.3
RC230	<0.6
RC240	<0.7
RC250	<2.5
RC260	<2.5
RC265	<1.5
RC270	<5
RC280	<5

The times relate to full air flow and may increase depending on solenoid valves and the dimensions of connecting pipes.



Torque Data – Double-Acting

RC200-DA

Model	Function	Position	Output Torque (Nm)*							
		0° = closed 90° = open	2.1 bar 30 psi	2.8 bar 40 psi	3.5 bar 50 psi	4.2 bar 60 psi	4.5 bar 65 psi	5.5 bar 80 psi	6 bar 87 psi	7 bar 100 psi
RC210	Air open/close	0°	13	17	21	25	27	35	38	44
		60°	6	8	10	12	13	17	19	22
		90°	9	12	15	18	19	25	27	32
RC220	Air open/close	0°	26	34	42	51	55	70	76	88
		60°	13	17	21	25	27	35	38	44
		90°	18	24	30	36	39	50	54	63
RC230	Air open/close	0°	48	64	80	96	103	133	145	165
		60°	24	31	39	47	50	66	72	83
		90°	35	46	57	69	74	96	105	120
RC240	Air open/close	0°	98	130	162	195	209	266	290	340
		60°	49	65	81	97	104	133	145	170
		90°	70	93	117	140	150	193	210	240
RC250	Air open/close	0°	150	200	250	300	321	413	450	530
		60°	75	100	125	150	161	206	225	260
		90°	108	143	179	215	230	293	320	380
RC260	Air open/close	0°	305	407	508	610	654	834	910	1070
		60°	150	200	250	300	321	422	460	530
		90°	220	293	367	440	471	596	650	770
RC265	Air open/close	0°	432	576	720	864	926	1188	1296	1512
		60°	203	271	338	406	435	556	606	711
		90°	307	409	512	614	658	844	921	1075
RC270	Air open/close	0°	630	840	1050	1260	1350	1733	1890	2200
		60°	315	420	525	630	675	862	940	1100
		90°	455	607	758	910	975	1247	1360	1590
RC280	Air open/close	0°	1270	1693	2117	2540	2721	3483	3800	4450
		60°	635	847	1058	1270	1361	1742	1900	2220
		90°	915	1220	1525	1830	1961	2512	2740	3190

* Output torque +/- 5%.

Torque Data – Spring-Return (spring to close)

RC200-SR

Model	Function	Position	Output Torque (Nm)*							
		0° = closed 90° = open	2.1 bar 30 psi	2.8 bar 40 psi	3.5 bar 50 psi	4.2 bar 60 psi	4.5 bar 65 psi	5.5 bar 80 psi	6 bar 87 psi	7 bar 100 psi
RC210	Air	0°	7	9	12	14	15	19	20	24
		60°	3	4	5	6	6	8	9	10
		90°	4	5	6	7.5	8	10	11	13
	Spring	90°	6	8	10	12	13	16	18	21
		30°	3	4	5	6	6	8	9	10
		0°	4	6	7	8.5	9	11	12	14
RC220	Air	0°	15	19	24	29	31	39	41	48
		60°	6	8	10	12	13	16	18	21
		90°	8	10	12	15	16	20	22	26
	Spring	90°	13	17	21	25	27	33	37	43
		30°	6	8	10	12	13	16	18	21
		0°	9	11	14	17	18	23	25	29
RC230	Air	0°	27	36	45	54	58	72	78	92
		60°	12	15	19	23	25	31	33	39
		90°	15	19	24	29	31	39	41	48
	Spring	90°	24	31	39	47	51	63	69	81
		30°	12	15	19	23	25	31	33	39
		0°	17	22	27	33	36	44	47	55
RC240	Air	0°	55	73	92	110	119	147	158	185
		60°	24	31	39	47	51	63	68	80
		90°	29	39	48	58	63	77	84	98
	Spring	90°	48	64	80	96	104	128	140	163
		30°	24	31	39	47	51	63	68	80
		0°	33	44	55	66	71	88	96	115
RC250	Air	0°	85	113	142	170	184	227	245	290
		60°	37	49	62	74	80	99	105	125
		90°	45	60	75	90	97	120	130	155
	Spring	90°	75	100	125	150	162	200	215	255
		30°	37	49	62	74	80	99	105	125
		0°	50	67	83	100	108	133	150	175
RC260	Air	0°	173	230	287	345	374	460	500	580
		60°	75	100	125	150	162	200	215	250
		90°	90	120	150	180	195	240	265	310
	Spring	90°	153	203	254	305	330	407	440	515
		30°	75	100	125	150	162	200	215	250
		0°	105	140	175	210	227	280	305	350
RC265	Air	0°	280	373	467	560	607	730	780	935
		60°	113	150	187	225	244	280	305	360
		90°	125	167	208	250	271	303	330	425
	Spring	90°	210	280	350	420	455	560	610	695
		30°	103	137	171	205	222	273	330	355
		0°	153	203	254	305	330	407	440	525
RC270	Air	0°	355	473	592	710	769	947	1030	1210
		60°	155	207	258	310	336	413	440	520
		90°	190	253	317	380	412	507	550	640
	Spring	90°	315	420	525	630	682	840	910	1060
		30°	155	207	258	310	336	413	440	520
		0°	215	287	358	430	466	573	620	720
RC280	Air	0°	715	953	1192	1430	1549	1907	2080	2430
		60°	310	413	517	620	672	827	900	1050
		90°	380	507	633	760	823	1013	1110	1290
	Spring	90°	635	847	1058	1270	1376	1693	1840	2150
		30°	310	413	517	620	672	827	900	1050
		0°	435	580	725	870	942	1160	1260	1470

* Output torque +/- 5%.

Note: Springs adapted to air supply pressure.

Torque Data – Spring-Return (spring to open)

RC200-SRF

Model	Function	Position	Output Torque (Nm)*							
		0° = closed 90° = open	2.1 bar 30 psi	2.8 bar 40 psi	3.5 bar 50 psi	4.2 bar 60 psi	4.5 bar 65 psi	5.5 bar 80 psi	6 bar 87 psi	7 bar 100 psi
RC210	Spring	0°	7	9.6	12	15	16	20	21	25
		60°	2.6	3.6	4.6	5.5	6	7.5	7.8	9
		90°	3	4.3	5.5	6.6	7	9	10	11.5
	Air	90°	5.2	7.2	9	11	12	15	16.2	19
		45°	2.8	3.8	4.9	6	6.4	8	9	10.1
		0°	4.5	6.2	8	10	10	13	14.3	17.2
RC220	Spring	0°	14	20	25	30	33	41	43	50
		60°	5.3	7.2	9	11	12	15	15.5	18
		90°	6.7	9	12	14	15	19	20	23
	Air	90°	11	14	18	22	24	30	33	38
		45°	5.6	7.7	9.8	12	13	16	18	21.5
		0°	9.4	13	16	20	22	27	30	34.5
RC230	Spring	0°	27	37	47	57	62	77	84	93
		60°	9.8	13	17	21	23	28	30	33
		90°	12	16	21	25	27	34	38	40
	Air	90°	21	29	37	44	48	60	62	75
		45°	11	15	19	23	25	31	33	41
		0°	17	23	29	36	39	48	51.5	66
RC240	Spring	0°	56	77	98	118	130	160	180	190
		60°	20	27	35	42	46	57	65	68
		90°	25	34	43	52	56	70	80	82
	Air	90°	42	58	73	89	97	120	123	155
		45°	22	31	39	47	52	64	66	84
		0°	35	48	61	74	81	100	97	135
RC250	Spring	0°	84	115	145	175	195	240	265	305
		60°	30	42	53	64	70	87	96	112
		90°	37	50	64	78	85	105	120	130
	Air	90°	65	89	110	135	150	185	195	225
		45°	34	47	60	73	79	98	104	123
		0°	54	74	98	115	125	155	160	195
RC260	Spring	0°	175	240	300	370	400	500	540	620
		60°	63	86	110	135	145	180	195	220
		90°	77	105	135	160	175	220	245	280
	Air	90°	135	185	230	280	310	385	400	465
		45°	70	96	120	150	330	200	210	250
		0°	110	150	190	230	520	315	330	395
RC265	Spring	0°	251	335	419	500	536	670	730	850
		60°	92	123	154	175	188	230	260	300
		90°	113	150	188	225	241	300	325	375
	Air	90°	188	250	313	375	402	500	525	620
		45°	101	135	169	200	214	260	290	335
		0°	158	210	263	315	338	400	445	525
RC270	Spring	0°	350	480	620	750	810	1010	1100	1250
		60°	130	175	2220	270	290	365	400	450
		90°	155	210	270	320	350	440	480	550
	Air	90°	270	370	470	570	620	770	830	1000
		45°	145	195	250	300	330	410	430	540
		0°	230	310	390	480	520	645	680	810
RC280	Spring	0°	730	1000	1270	1540	1670	2080	2250	2500
		60°	260	360	460	550	600	750	780	820
		90°	320	440	560	680	740	920	1000	1100
	Air	90°	560	770	980	1180	1290	1600	1700	2000
		45°	290	400	510	620	670	835	900	1100
		0°	460	630	805	980	1060	1320	1380	1700

* Output torque +/- 5%.

Note: Springs adapted to air supply pressure.



A full listing of our worldwide sales and service network is available on our website.

Corporate Headquarters
Rotork plc
tel +44 (0)1225 733200
fax +44 (0)1225 333467
email mail@rotork.com

www.rotork.com

Fluid Systems
Fluid Power Actuators and Control Systems

Controls
Electric Actuators and Control Systems

Gears
Gearboxes and Gear Operators

Site Services
Projects, Services and Retrofit

All Rotork Fluid Systems actuators are manufactured under a third party accredited ISO9001:2000 quality assurance programme. As we are continually developing our products, their design is subject to change without notice.

The name Rotork is a registered trademark. Rotork recognises all registered trademarks. Published and produced in the UK by Rotork Fluid Systems. POWTG0310